

QUALITY SYSTEM
ISO 9001

BR - BRM

Rulli standard / Standard rolls

fig. 1 taglio / cut
fig. 2 bordura piana / flat beading
fig. 3 gradino / step

mm	BRM / BR..	48	56	65
fig. 4 r =		1,5	2,0	2,0
fig. 5 r =		2,0	2,5	2,5
fig. 6 r =		2,5	3,0	3,0
fig. 7 r =		3,0	4,0	4,0
fig. 8 r =		2,5	2,5	3,0

Dimensioni
Dimensions

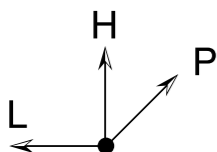

mm	L	P	H
BRM 48	550	1000	1400
BRM 56	620	1100	1400
BRM 65	1050	720	1500
BR 48	580	330	520
BR 56	680	370	570
BR 65	810	410	640

Bordatrici motorizzate e manuali Motorized or manual beading machines



Modello / Model	BRM 48	BRM 56	BRM 65
Articolo / Item	A104100	A105100	A106100
Interasse alberi / Distance between shafts axis	48 mm	56 mm	65 mm
Spessore lamiera / Plate thickness	0,8*	1,0*	1,5*
Profondità gola al centro rulli / Groove depth in the center of rolls	210 mm	260 mm	320 mm
Velocità di lavoro (giri/min) / Working speed (r.p.m.)	20 ÷ 100	20 ÷ 100	20 ÷ 100
Chiusura rulli / Rolls closing	(M)	(M)	(M) - (P)
Potenza assorbita / Absorbed power	0,22 kW	0,55 kW	0,75 kW
Tensione di alimentazione / Voltage	400V, ~3, 50/60 Hz		
Peso / Weight	85 kg	135 kg	170 kg

Modello / Model	BR 48	BR 56	BR 65
Articolo / Item	A102000	A103000	A104000
Interasse alberi / Distance between shafts axis	48 mm	56 mm	65 mm
Spessore lamiera / Plate thickness	0,8*	1,0*	1,5*
Profondità gola al centro rulli / Groove depth in the center of rolls	210 mm	260 mm	320 mm
Chiusura rulli / Rolls closing	(M)	(M)	(M)
Peso / Weight	42 kg	65 kg	95 kg

CSM-CSL

Cesoie a ghigliottina motorizzate e a leva Motorized guillotine and level shears

Dimensioni
Dimensions

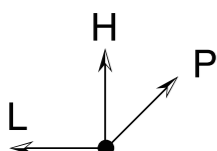

mm	L	P	H
CSM 10/3	1650	1300	1300
CSM 15/2,5	2150	1300	1300
CSM 20/2	2650	1300	1300

Dimensioni
Dimensions

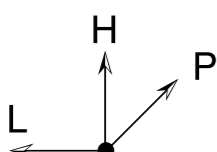

mm	L	P	H
CSL 520	1350	600	450
CSL 750	1250	800	900
CSL 1020	1550	1050	1100

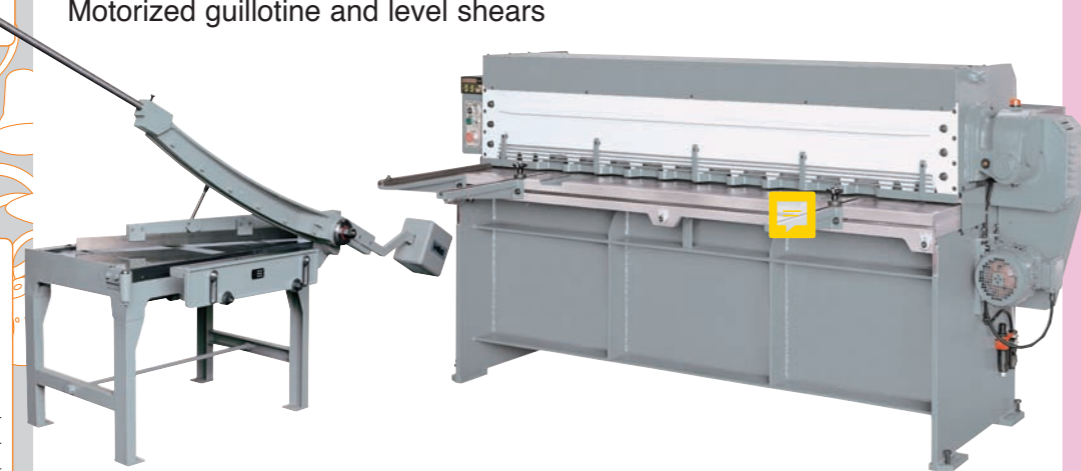

Modello / Model	CSM 10/3	CSM 15/2,5	CSM 20/2
Lunghezza utile taglio / Max cutting length	1050 mm	1250 mm	2050 mm
Profondità incavo / Gap depth	150 mm	150 mm	150 mm
Velocità di lavoro / Working speed	60 colpi/ min	60 colpi/ min	60 colpi/ min
Spessore lamiera / Sheet thickness	3,0 mm *	2,5 mm *	2,0 mm *
Registro posteriore / Backgauge travel	500 mm	500 mm	500 mm
Potenza assorbita / Absorbed power	3 kW	3 kW	3 kW
Tensione di alimentazione / Voltage	230V, ~1, 50/60 Hz		
Peso / Weight	1300 kg	1500 kg	1750 kg

Modello / Model	CSL 520	CSL 750	CSL 1020
Articolo / Item	A401000	A405000	A406000
Lunghezza utile taglio / Max cutting length	520 mm	750 mm	1020 mm
Registro posteriore / Backgauge travel	300 mm	380 mm	550 mm
Spessore lamiera / Sheet thickness	0,8 mm*	1,0 mm*	2,0 mm*
Peso / Weight	75 kg	220 kg	385 kg