

QUALITY SYSTEM
ISO 9001

TLA DIMAIKA

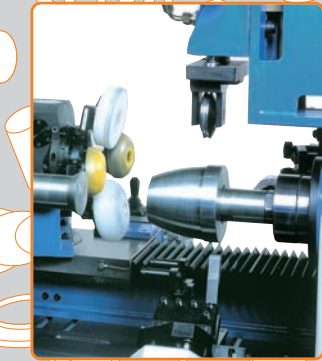

Torni lastra automatici serie TLA DIMAIKA
TLA DIMAIKA automatic spinning lathes

- a CNC e consolle di comando (versione TLA)
- b Pannello di comando utensili (versione TL)
- c Utensile bordatore
- d Toretta automatica portautensili
- e Centralina oleodinamica
- f Mandrino porta modello
- g Utensile rifilatore
- h Utensili modellatori
- i Contropunta pneumatica
- j Premiamiera
- k Slitta asse X
- l Slitta asse Y

- a CNC control on electric board (TLA type)
- b Spinning tools control board (TL type)
- c Riming tool
- d Revolving tool holder turret
- e Hydraulic unit
- f Splinde
- g Trimming tool
- h Spinning rolls
- i Pneumatic tailstock
- j Blank holder
- k X axis slide
- l Y axis slide

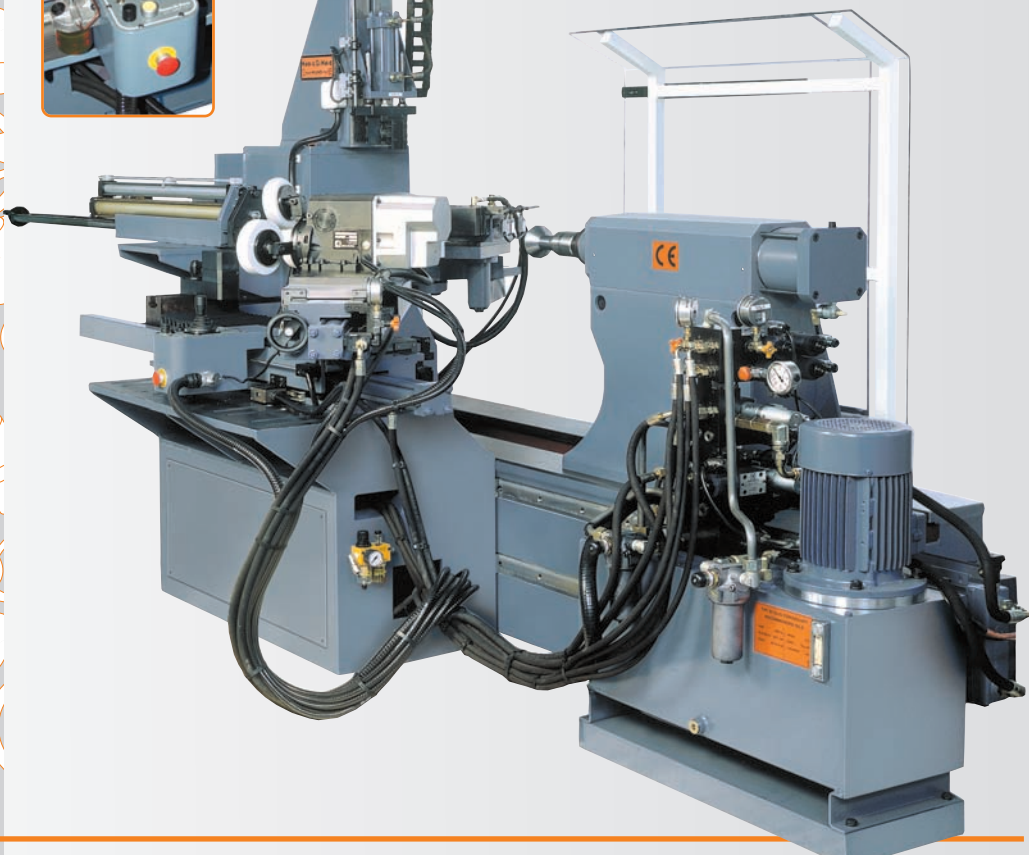
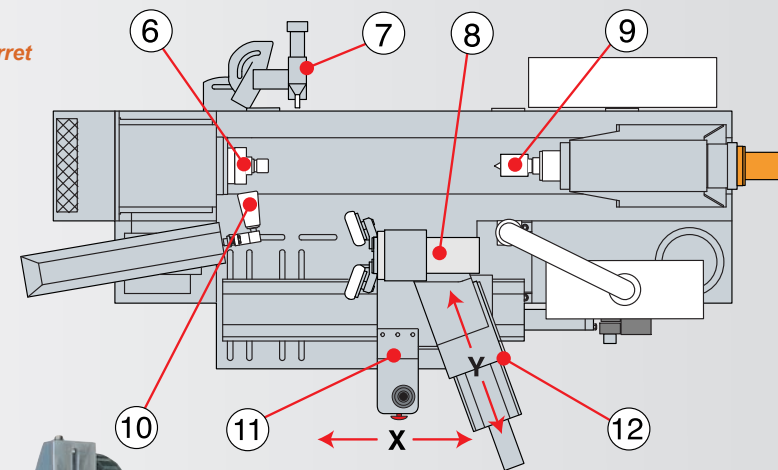
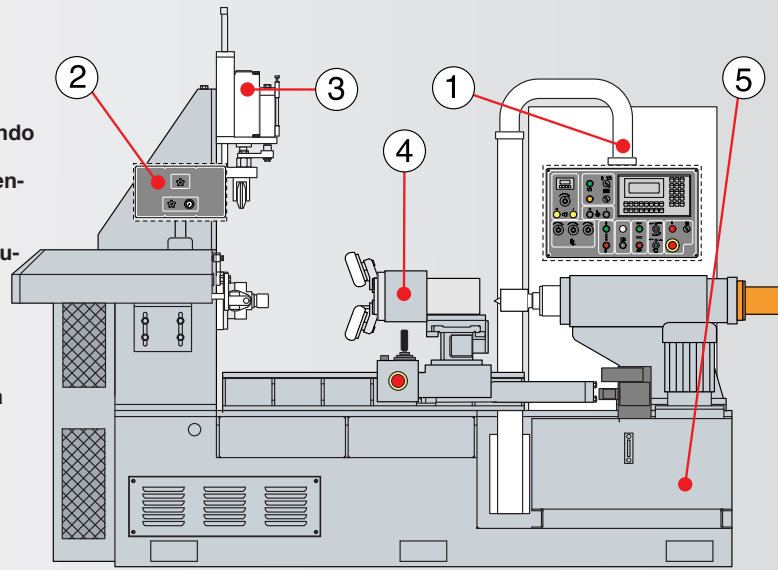

Rulli formatori per tornitura lastra
Forming rolls for spinning

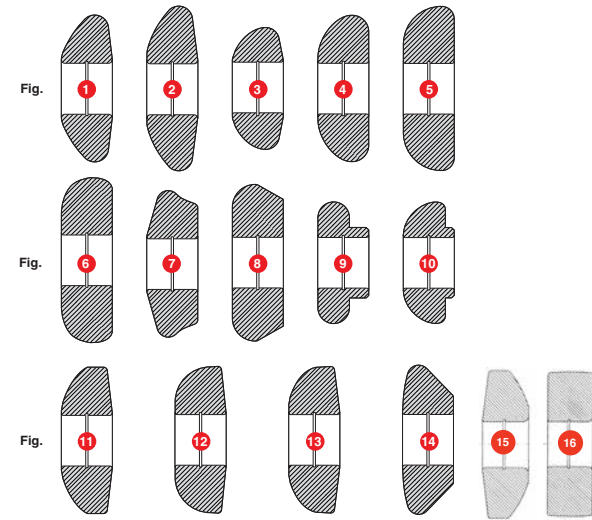

Fig.	ref.	Ø
1	51424	ø 118 mm
2	65684	ø 130 mm
3	61821	ø 96 mm
4	51595	ø 118 mm
5	55241	ø 130 mm
6	65275	ø 130 mm
7	54009	ø 118 mm
8	52513	ø 124 mm

Fig.	ref.	Ø
9	61817	ø 96 mm
10	61823	ø 96 mm
11	51492	ø 116 mm
12	51597	ø 116 mm
13	54001	ø 116 mm
14	54008	ø 118 mm
15	69781	ø 130 mm
16	69787	ø 130 mm

Rulli finitori per tornitura lastra - Finishing rolls for spinning

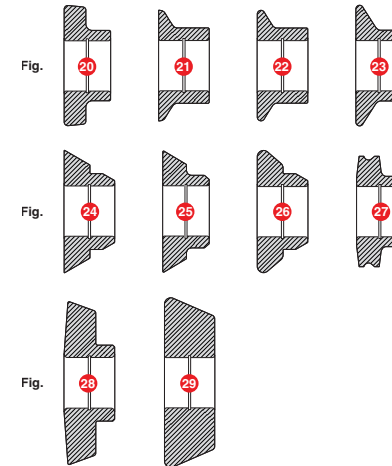

Fig.	ref.	Ø
20	61818	ø 98 mm
21	54004	ø 88 mm
22	60538	ø 88 mm
23	61819	ø 96 mm
24	52565	ø 98 mm

Fig.	ref.	Ø
25	61822	ø 96 mm
26	52514	ø 98 mm
27	61820	ø 88 mm
28	64884	ø 130 mm
29	65276	ø 130 mm

Rulli bordatori per tornitura lastra - xxxxxxxx rolls for spinning

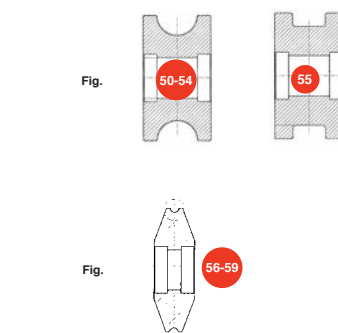

Fig.	ref.	Ø	Ø gola/largh.gola
50	69782	ø 93 mm	ø 35 mm
51	69783	ø 93 mm	ø 32 mm
52	69784	ø 93 mm	ø 30 mm
53	69788	ø 93 mm	ø 38 mm
54	69789	ø 93 mm	ø 24 mm
55	69790	ø 93 mm	ø 24 mm
56	65281/01	ø 93 mm	ø 6 mm
57	65281/02	ø 93 mm	ø 12 mm
58	65281/03	ø 93 mm	ø 18 mm
59	65281/04	ø 80 mm	ø 1,2 mm

Materiale rullo
Roll material

Materiale lavorato
Worked material

	Acciaio Inox <i>Stainless Steel</i>	Fe	Al	Ottone <i>Brass</i>	Cu
Acciaio temprato / <i>Hardened steel</i>	<input checked="" type="checkbox"/>	<input checked="" type="checkbox"/>	<input checked="" type="checkbox"/>	<input checked="" type="checkbox"/>	<input checked="" type="checkbox"/>
Bronzo / <i>Bronze</i>	<input checked="" type="checkbox"/>	<input checked="" type="checkbox"/>			
Teflon®			<input checked="" type="checkbox"/>		
Resina sintetica / <i>Synthetic resin</i>			<input checked="" type="checkbox"/>	<input checked="" type="checkbox"/>	<input checked="" type="checkbox"/>